

/ External dimensions and workable space /

Detailed drawing of end-effector mounting face

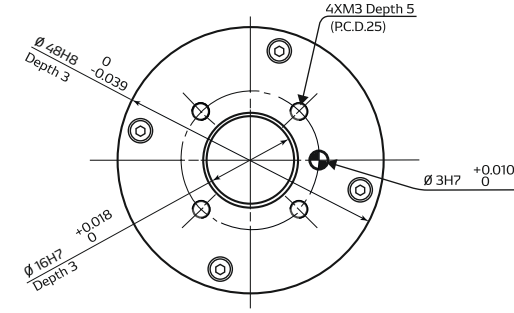

Detailed drawing of base mounting face

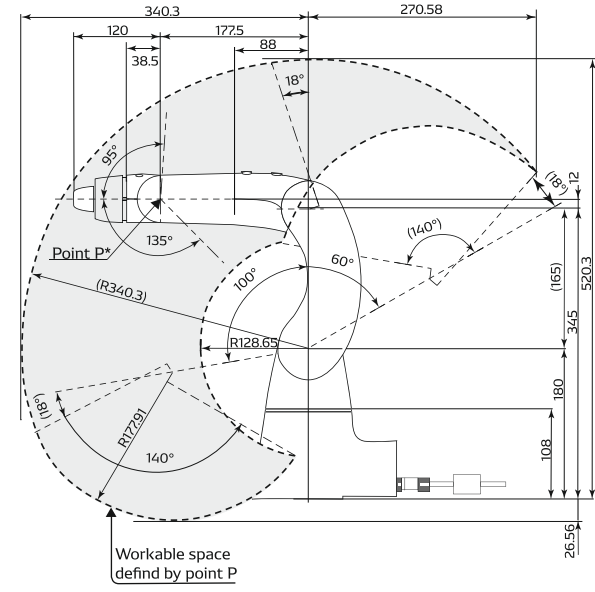
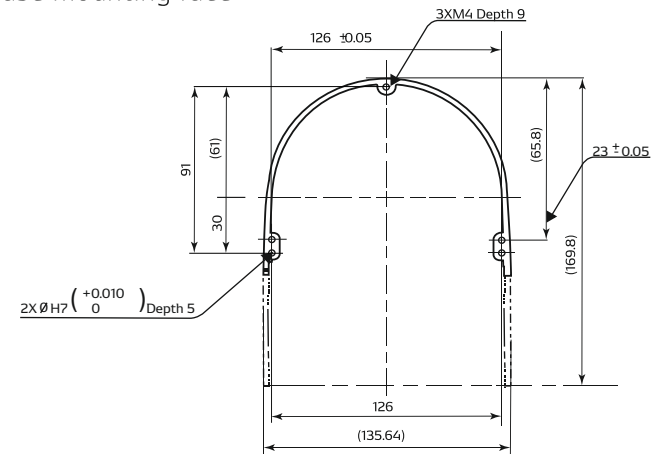

Without gripper

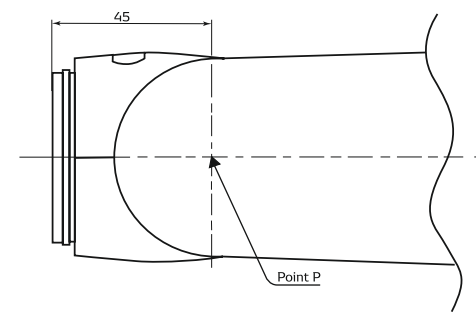

	Gripper weight: 0.20 kg Camera weight: 0.213 kg <i>*Convert to 0.15 kg when camera is attached as option on</i>	Payload	
		All directions (No limit of angles)	Wrist downward (+10 degrees)
1) Gripper: No Camera: No		0.50 kg	0.70 kg
2) Gripper: Yes Camera: No		0.30 kg	0.50 kg
3) Gripper: No Camera: Yes		0.35 kg	0.55 kg
4) Gripper: Yes Camera: Yes		0.15 kg	0.35 kg

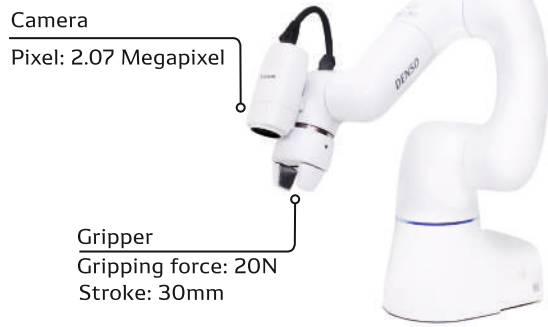

COBOTTA

COLLABORATION ROBOT TECHNOLOGY FOR ARM



COBOTTA

/ Anywhere, anytime, always safe /



PARTS FEEDING



ASSEMBLY OF 3-COLOUR PENS



EDUCATION



European Headquarters: DENSO Robotics Europe DENSO EUROPE B.V. Waldeckerstr.9, 64546 Moerfelden-Walldorf Germany
www.densorobotics-europe.com

Contact us: t: +49 (0) 6105 27 35 150 f: +49 (0) 6105 27 35 180
Commercial information: info@densorobotics-europe.com
Technical support: support@densorobotics-europe.com

DENSO Inventor of the QR Code
QR Code to our COBOTTA video



COBOTTA

/ For Human Robot Collaboration /



INHERENTLY SAFE DESIGN & FUNCTIONAL SAFETY

The unique design of COBOTTA has no sharp edges or pinch points and ensures safe collaboration with humans. In addition, there are sensors built into the six axis for constant monitoring of speed and torque, to guarantee functional safety as well.



BUILT-IN CONTROLLER

COBOTTA features a controller fully integrated in the robot arm – a unique DENSO Robotics design. This offers many advantages including a low total weight of only 4 kg, a small operation area and easy transportation. The controller also facilitates consolidated control with other devices.



OPEN PLATFORM

The integrated controller consists of an open platform, allowing developers to create their own applications in the environment they choose (OSS version). In addition to DENSO Robotics' standard OS and programming possibilities, the robot is compatible with various programming languages for individual development environment (Linux ROS) and can be connected to all kinds of devices. ORiN is supported.



EASY TO USE

COBOTTA offers a direct teaching function and an intuitive GUI for easy programming. The built-in A/F camera and the built-in electrical gripper combined with the standard programming Apps allows creating new applications quickly – even for users not yet familiar with robots.



PORTABLE BODY

The COBOTTA arm with the integrated controller only weighs 4 kg, providing easy portability and maximum flexibility, i. e. to combine the robot with mobile platforms. The integrated controller reduces both the wiring and the required working space. Transporting and installing COBOTTA anywhere anytime is simply easy.

EASY PROGRAMMING

Cobotta World is a teaching assistant application exclusively designed for COBOTTA. The application helps you easily and quickly teach COBOTTA a desired job. Moving your COBOTTA directly, you can teach a desired job sequence by simply selecting and aligning jobs from the preset job items.

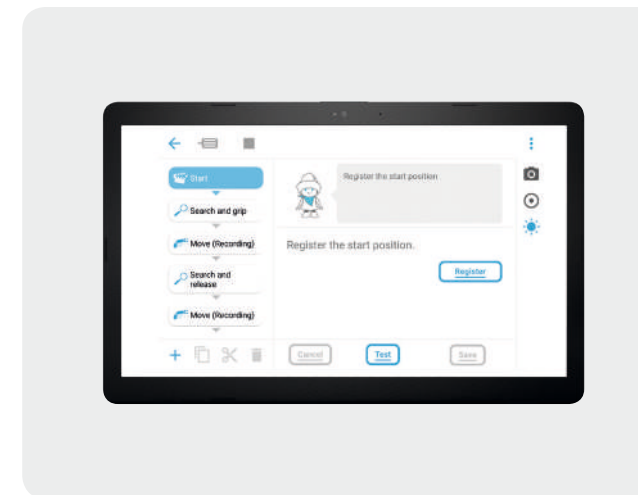

Specifications

Axes	6+1 (for an electric gripper) (1)
Drive motor / brake	All axes AC servo motor/J1 to J5 with brake
Total arm length (1st arm + 2nd arm)	342.5 (165 + 177.5) mm
Rated load capacity (Maximum payload)	0.5 kg (*0.7 kg wrist direction downward within +/- 10 degrees) (2)
Position repeatability	+/-0.05mm (3)
Maximum composite speed (center of tool mounting face)	Default 500 (min. 100 to max. 1000) mm/s
Protected type	IP30
Software	Standard type: COBOTTA dedicated software, OSS type: none (3)
Power supply specifications (AC adaptor)	Input: single-phase 230 V /Output: 24 VDC (approx. 180 W)
External signal	System fix input: 12 ports/ System fix output: 10 ports User open input: 8 ports / User open output: 10 ports Additional external switch emergency stop device
External communication	Ethernet, 2x USB, Field Network prepared for EtherCAT, ProfiNet, EtherNet/IP
Weight	Approx. 4 kg
Standards for safety	ISO 10218-1:2011 ISO/TS 15066:2016 ISO 13849-1:2015 PL d Cat. 3 TÜV Rheinland

(1) Options. (2) Without electric gripper. (3) At fixed ambient temperature or lower.

System configuration

OPTION

- AF camera ¹
- Electric gripper for COBOTTA
- Mini I/O cable
- VGA relay cable ²

STANDARD INCLUDED ITEMS

- AC adapter / AC cable ³
- Manual disc
- Software DVD for COBOTTA
- COBOTTA World (App) ⁴
- WINCAPS III ⁵, remote TP (App) ⁴
- EVP (Easy Vision Picking) ⁵

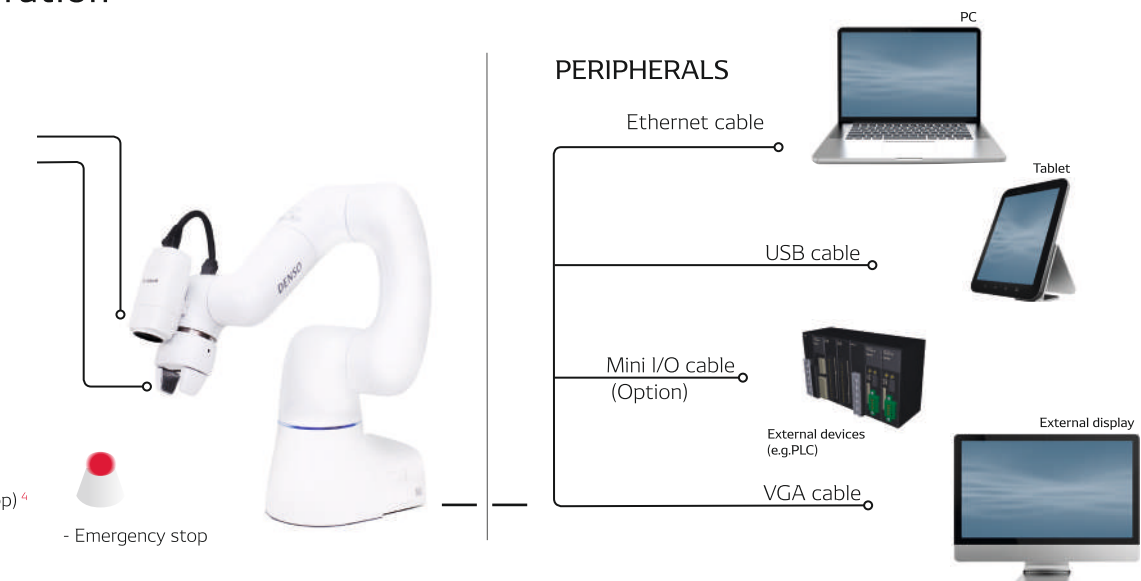

¹ The hub must have a PoE supply function for use. ² Used to display the COBOTTA development screen when using the OSS version. ³ To be selected matched to power outlets in the country of use. ⁴ Android OS applications can be downloaded from Google Play Store. ⁵ To be installed in a tablet or PC.