

External dimensions and workable space (unit: mm)

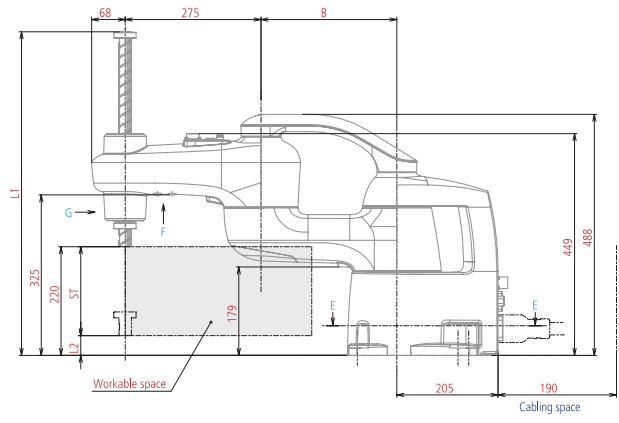

Model	A	B	C	D	E
HSR048A1-N*	480	205	164.4	287°	406.53
HSR055A1-N*	550	275	142.4	300°	364.32
HSR065A1-N*	650	375	194.0	300°	287.62

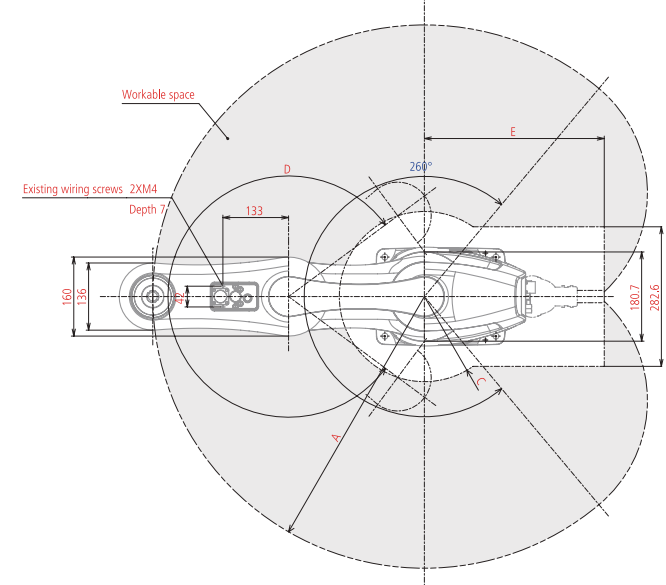

Z-axis stroke : ST (mm)	L1	L2
* =10 : 100	555.2	120
* =20 : 200	655.2	20
* =32 : 320	775.2	-100 Note 1
* =51:510 Note 2	965.2	-290 Note 1

Note 1: Be noted that if Z is 320mm, 510mm the lowest point of the Z-axis will achieve a position lower than the base mounting face.
 Note 2: Models with a Z-axis stroke of 510mm will be available in and after 2019.

Z-axis stroke correspondence table

Vertical stroke (Z)(mm) *	Standard type	Dust & splash proof type	Cleanroom type	Bellows type	Metal detectable bellows type	Dust & splash proof type (IP65 / Metal detectable bellows)
100	○	○	○	○	○	○
120	○	○	○	○	○	○
170	○	○	○	○	○	○
200	○	○	○	○	○	○
240	○	○	○	○	○	○
290	○	○	○	○	○	○
320	○	○	○	○	○	○
450	○	○	○	○	○	○
510	○	○	○	○	○	○

Positions of existing wiring and piping securing screws

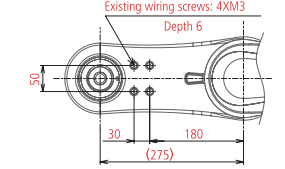

Detailed drawing of end-effector mounting face (View G)

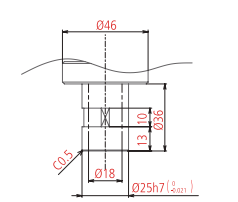

Flange (Option) Mounting Drawing

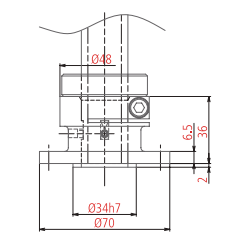

Base Mounting Dimensions (E-E cross section)

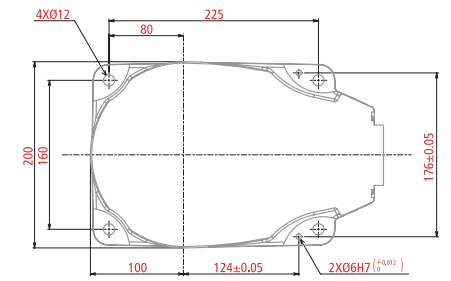

*1: Models with a Z-axis stroke of 120, 240, 450, or 510mm will be available in and after 2019.

RC8A Robot Controller Development Code No.8

Specifications

Item	Specifications
Power supply	1.80 kVA (Adaptable robot: HSR Series)
Input voltage range	Three-phase, 200 VAC -15% to 240 VAC +10% Single-phase, 230 VAC -10% to 240 VAC +10%
Power supply frequency	50 / 60 Hz
Power cable length	5 m
Controllable axes	4
Control method	PTP, CP 3-dimensional linear, 3-dimensional arc (PTP control only for additional axes)
Drive method	Digital AC servo on all axes
Language used	DENSO robot language (PacScript)
Memory capacity	User area—Variable area: 1.75 MB (equivalent to 32,766 points); File area: 400 MB (5,000 steps x 256 files)
Teaching system	1) Remote teaching, 2) Numerical entry (MDI), 3) Direct teaching (HS series, HM series, HSR series)
Mini I/O	Standard type/safety motion type Input: User open 8 points + system fix 14 points / Output: 8 open user points + 18 fixed system points
Safety I/O less type	Input: User open 8 points + system fix 13 points / Output: 8 open user points + 14 fixed system points
Hand I/O	Input: User open 8 points / Output: 8 open sur
Motion I/O (option)	Input: Safety circuit signal: 30 points / Output: Safety circuit signal: 14 points
Parallel I/O board (option)	Expansion slot: PCI / Input: 40 points / Output: 48 points
External signal (I/O, etc.)	Expansion slot: PCI Express / Input: 8,192 points max. / Output: 8,192 points max. Remote register input: 2,048 words max. / Output: 2,048 words (*1)
DeviceNet slave board (option)	Expansion slot: PCI Express / Input: 256 points max. / Output: 256 points max.
DeviceNet master board (option)	Expansion slot: PCI Express / Input: 1,024 points / Output: 1,024 points
EtherNet / IP adapter board (option)	Expansion slot: PCI Express / Input: 4,032 points max. / Output: 4,032 points max.
PROFIBUS slave board (option)	Expansion slot: PCI Express / Input: 256 points max. / Output: 256 points max.
PROFINET I/O device board (option)	Expansion slot: PCI Express / Input: 8,192 points max. / Output: 8,192 points max.
EtherCAT slave board (option)	Expansion slot: PCI Express / Input: 2,048 points max. / Output: 2,048 points max.
External communication	RS-232C: 1 line, Ethernet: 1 line (GbE: Gigabit Ethernet), USB: 2 lines, VGA: 1 line (option)
Expansion slot	PCI: 1 slot, PCI Express: 1 slot
External-diagnosis function	Overrun, servo error, memory error, input error, short circuit detection (user wiring part), etc.
Environmental condition (in motion)	Temperature: 0 to 40°C Humidity: 20-90% RH or less (no condensation allowed)
Protection rating	IP20
Weight	Safety I/O less type, standard type: approx. 10 kg, safety motion type: approx. 11 kg (*2)

*1 For Ver. 2.00 *2 Does not include the supplied cables.
 Compliant robot safety standards :
 ISO 10218-1: 2011, ANSI/RIA R15.06-1999
 UL standards UL1740, CSA 2434, etc.



DENSO newest and most advanced robot controller
 Dimensions: 356.5 × 319.6 × 93.8 mm

Outer dimensions (mm)

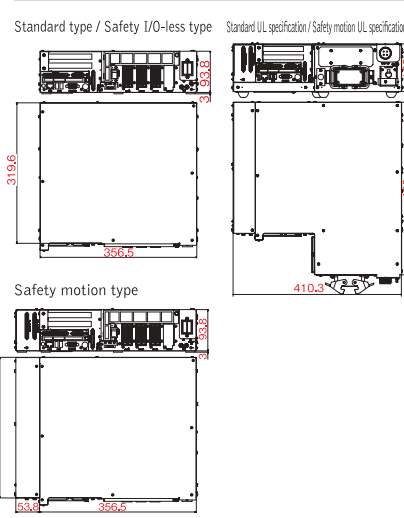

Optional systems diagram

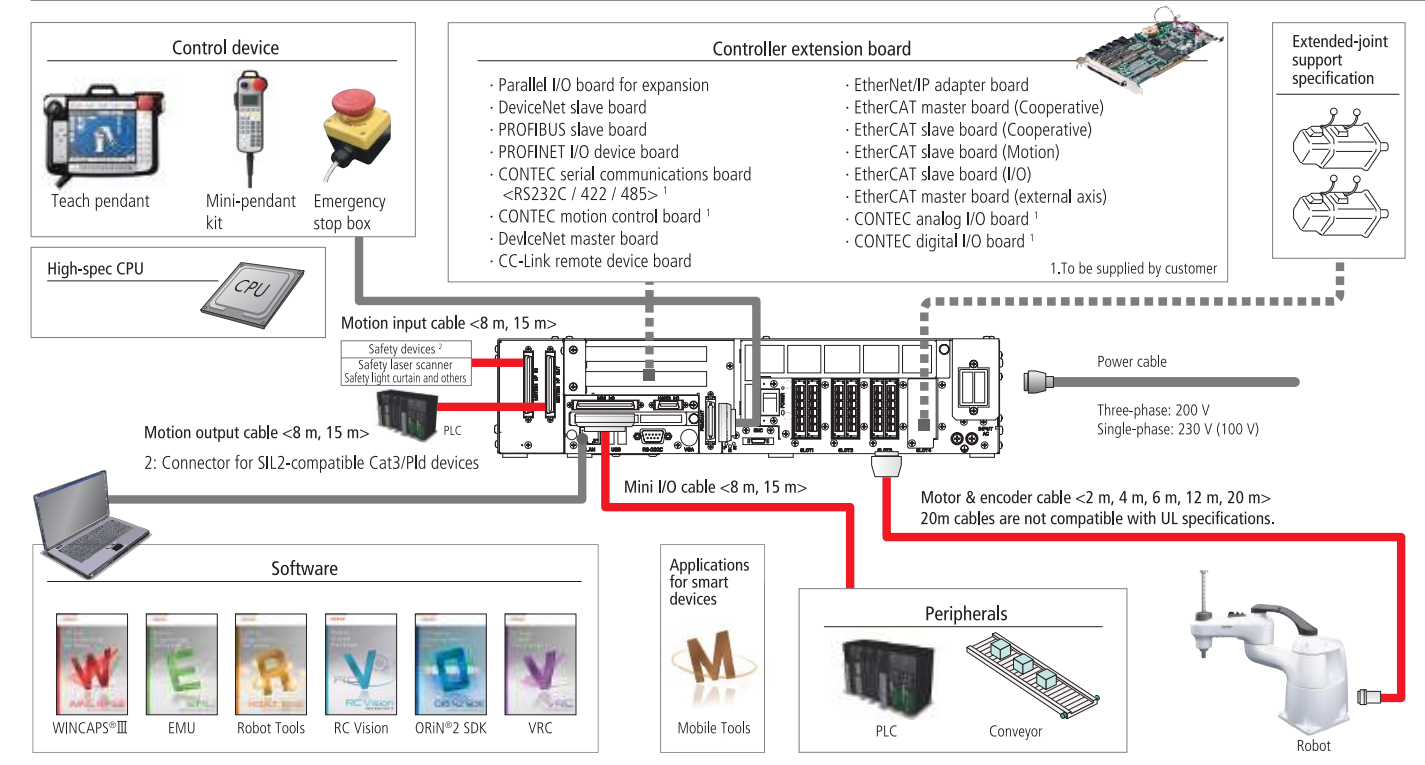

HSR SERIES
 HSR048/HSR055/HSR065



True high speed performance that changes everything

Legend

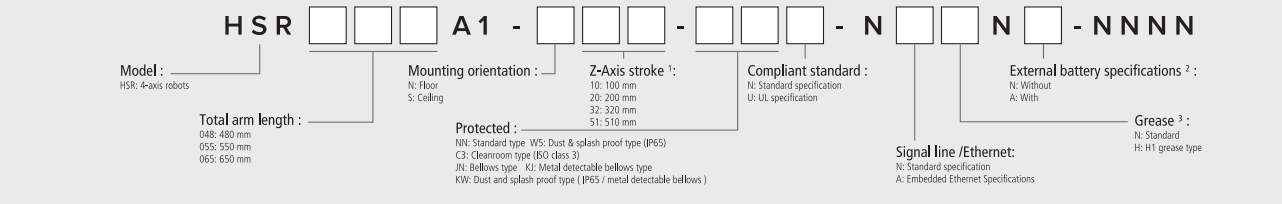

*1: Available standard type Z-axis strokes are 100mm, 200mm, 320mm and 510mm. For other variations, please check the above table. *2: The external battery extension unit is sold separately. *3: Dust and drip-proof types are also available for selection.

DENSO WAVE INCORPORATED Website: <https://www.denso-wave.com/en/robot/>

DENSO Products and Services Americas, Inc.	3900 Via Oro Avenue, Long Beach, California, 90810, U.S.A.	Phone : +1-888-476-2689	FAX : +1-310-952-7502
DENSO KOREA CORPORATION	131, Seonggogae-ro, Uiwang-si, Gyeonggi-do, Korea 437-120	Phone : +82-31-340-1783	FAX : +82-31-8033-7213
DENSO TAIWAN CORP.	No.525 Sec.2, Mei Su Road, Jui Ping Li, Yang-Mei Town, Taoyuan Hsien, Taiwan	Phone : +886 3-482-8001	FAX : +886 3-482-8003
DENSO EUROPE B. V. DENSO Robotics Europe	Waldeckstrasse 9 D-64546 Moerfelden-Walldorf, Germany	Phone : +49-6105-27-35-150	FAX : +49-6105-27-35-1180
DENSO (CHINA) INVESTMENT CO., LTD.	No.35 Yuandian Road, Minhang District, Shanghai, CHINA 201108	Phone : +86-21-2350-0093	FAX : +86-21-2350-0179
DENSO SALES (THAILAND) CO.,LTD.	888 Moo 1, Bangna-Trad Rd. Km 27.5, T.Bangbor, A.Bangbor, Samutprakarn, 10560, Thailand	Phone : +66-2-315-9500	FAX : +66-2-315-9556



P4-HSR-E 201906

Quick Acceleration. Runs Continuously at High Speed. Stops Precisely.

High-speed motion

High acceleration & motion profiles
Improved CPM (cycle per minute) allows the robot to move at high speed continuously.

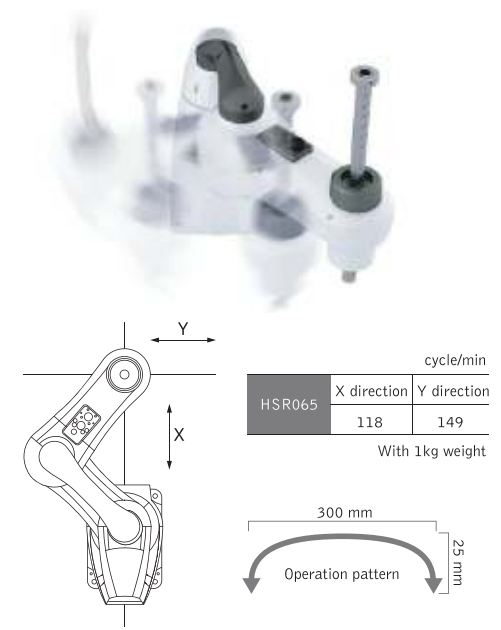

* CPMs differ according to the coordinates.

Light weight

Newly designed, highly rigid, lightweight arm
The combination of between high rigidity and light weight allows the robot to achieve a high payload (8kg) and high-speed motion at the same time.

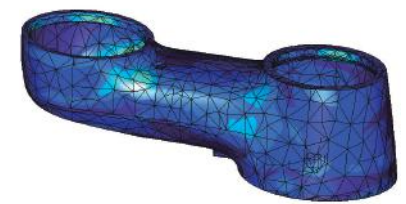

Continuous motion

Achieving Non-Stop continuous motion
Improved heat dissipation performance at the base unit allows the robot to achieve continuous motion, which is required in actual processes.



Vibration control

Vibration control technique for suppressing vibrations
The robot can suppress vibrations in a short time by actively reflecting the status of the arm to vibration control. This can suppress vibrations that occur with high-speed transfer and residual vibrations, reducing the cycle time.

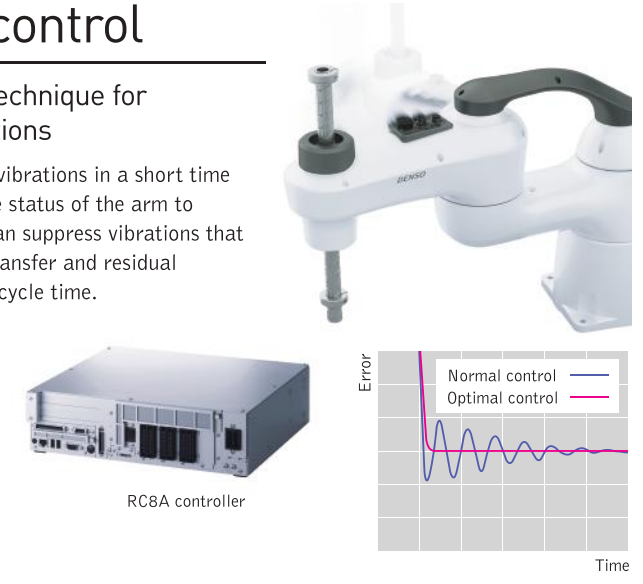

HSR Series

DENSO 4-axis Robot
SCARA robot

Robot controller supported **RC8A**

HSR048/HSR055/HSR065

Best-in-class high-speed/high throughput performance allows the robot to run continuously at maximum speed in the most challenging applications.
Metal detectable bellows type is newly available.

Maximum reach	480*550*650 mm
Z-axis stroke	100*200*320*510 mm ⁴
Maximum payload	8 kg
Cycle time	0.28 and 0.31 sec
Position repeating accuracy	±0.01*0.012 mm



Specifications

Term	Specifications		
Model ¹	HSR048A1-N/S*	HSR055A1-N/S*	HSR065A1-N/S*
Total arm length (J1: No.1 arm + J2: No.2 arm)	205+275=480mm	275+275=550mm	375+275=650mm
Motion range and stroke	J1 (No.1 axis)	±130°	
	J2 (No.2 axis)	±143.5°	
Z (No.3 axis) *	* =10 : 100mm		
	* =20 : 200mm		
	* =32 : 320mm		
	* =51 : 510mm ⁴		
T (No.4 axis)	±360°		
Axis combinations	J1 (No.1 axis) + J2 (No.2 axis) + Z (No.3 axis) + T (No.4 axis)		
Maximum payload	8kg		
Cycle time ²	0.28sec	0.28sec	0.31sec
Maximum joint speed	J1	450deg/sec	450deg/sec
	J2	785deg/sec	785deg/sec
	Z	10:1700mm/sec, 20:2300mm/sec, 32:2475mm/sec	
	T	2500deg/sec	
Position repeatability (center of end-effector mounting face) ³	J1+J2	±0.01mm	±0.012mm
	Z	±0.01mm	
	T	±0.004°	
Maximum pressure input (downward)	98N (1 second or less)		
Maximum allowable moment of inertia	0.12kgm ²		
Position detection method	Absolute encoder		
Drive motor / brake	All-axis servo motor / Z- and T-axis brake		
User air pipe	4 systems (Ø4×2, Ø6×2)		
User signal line	19 (for proximity sensor signals, etc.) Ethernet (8) *Option		
Air source	Normal pressure	0.05 to 0.35MPa	
	Maximum allowable pressure	0.59MPa	
Airborne noise	80 dB or less		
Weight	Approx. 31 kg	Approx. 31.5 kg	Approx. 32 kg

1: An asterisk [*] in a model name indicates Z-axis stroke.
2: Time required for a robot to move a 2 kg payload between two points 300 mm apart at a height of 25 mm.
3: Position repeatability is the precision at constant ambient temperature.
4: Models with a Z-axis stroke of 510 mm will be available in and after 2019.

Options

Wiring protection kit



Protects external wiring to prevent cables from becoming unorganized and avoid the risk of broken wires.

Built-in Ethernet



An Ethernet cable is built into the body. Easily connectable to external devices. *Ethernet connectors (sold separately) are available as options.

External battery



The encoder backup battery installed outside the robot facilitates easy replacement of batteries and makes maintenance.

Stopper with bearing



This stopper can protect wiring that is installed through the hole of the bearing located at the top of the Z-axis shaft.

Optimum layout

Optimized layout allows the robot to achieve high-speed motion.

A large-capacity motor is integrated into the base unit. Weight reduction at the tip of the arm and optimized arm structure allow the robot to improve its high-speed performance.



Improved flexibility in mounting direction

The mounting direction can be switched

You can select from the floor type and the ceiling type.

* Contact us when you want to change mounting direction.



True High Speed performance never seen before has been achieved

Sometimes, the performance of a robot cannot be known only from its specifications. You may not be confident whether it can complete the motion within the listed cycle time, or whether it can actually continue its motion. To address those challenges, we have pursued the basic performances of robots—quick acceleration; runs continuously at high speed; stops precisely—that have been requested from fields to the utmost limits, and have developed new high-speed SCARA robots, the HSR Series, that can achieve "True high-speed performance." As a result of pursuing high-speed performance, high-speed picking systems can be realized with small, space-saving robots not only in conventional parts assembly processes, but also in packaging processes of food, medical supplies, and cosmetics, which is bringing about a revolution in performance.